

D-Thread Mill-Thread Inserts & Toolholders for machining deep threads

- Improved productivity due to multi-insert toolholders.
- Partial Profile, standard or U-type inserts for a wide range of threads.
- Inserts with three cutting edges, reduces tooling costs.
- Low cutting resistance due to the single point inserts.
- Holder allows a long overhang and includes internal coolant.
- Same insert and toolholder for both external and internal thread.

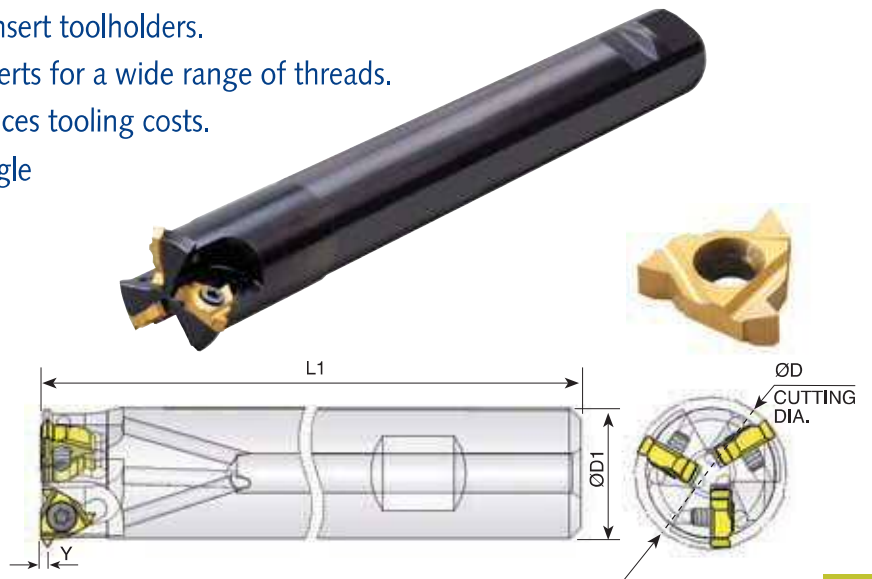

Ordering Code	Insert Size		Y	D	D1	L1	No. of Inserts	Insert Screw	Torx Key
	L	I.C.							
SR0023Q11	11	1/4	1	23.5	20	190	3	SE11	K11

Partial 60° Size 11

Ordering Code		Pitch	
		mm	TPI
1160D	INT.	1.0 -2.0	24-12
	EX.	0.75-1.5	32-14

Coated Grade: BMA

Partial 55° Size 11

Ordering Code		Pitch TPI
1155D	INT./EX.	24-14

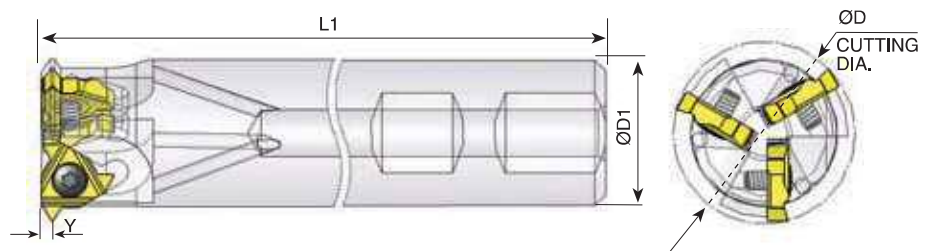
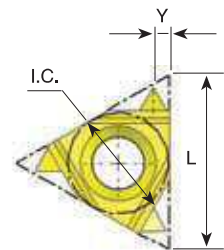

Ordering Code	Insert Size		Y	D	D1	L1	No. of Inserts	Insert Screw	Torx Key
	L	I.C.							
SR0031R16	16	3/8	1.8	31	25	225	3	SE16	K16

Partial 60° Size 16

Ordering Code		Pitch	
		mm	TPI
1660D	INT.	2.5-3.5	10-7
	EX.	2.0-3.0	12-8

Coated Grade: BMA

Partial 55° Size 16

Ordering Code		Pitch TPI
1655D	INT./EX.	12-8

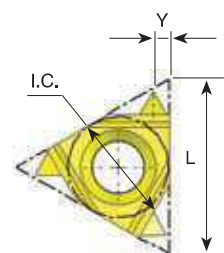

D-Thread Mill-Thread Inserts & Toolholders for machining deep threads

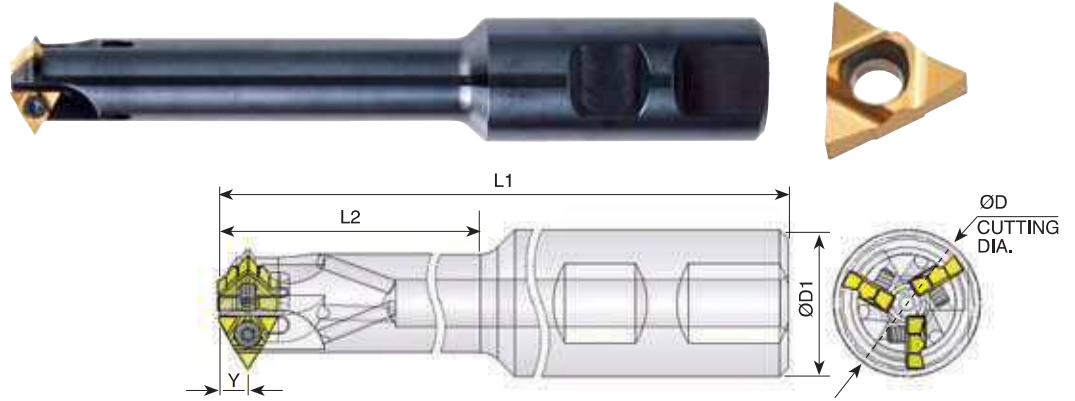

Ordering Code	Insert Size		Y	D	D1	L1	L2	No. of Inserts	Insert Screw	Torx Key
	L	I.C.								
SR0023M11U	11U	1/4U	5	23	25	150	88	3	SE11	K11

Partial 60° Size 11U

Ordering Code		Pitch	
		mm	TPI
11U60D	INT.	2.5-4.0	10-6
	EX.	2.0-3.0	12-8

Coated Grade: BMA

Partial 55° Size 11U

Ordering Code		Pitch
		TPI
11U55D	INT./EX.	12-7

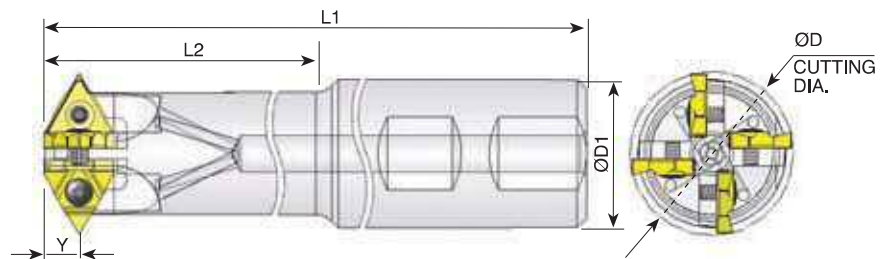
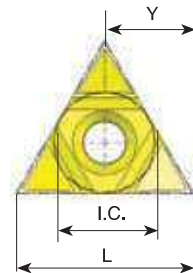

Ordering Code	Insert Size		Y	D	D1	L1	L2	No. of Inserts	Insert Screw	Torx Key
	L	I.C.								
SR0035R16U	16U	3/8U	7.6	35.5	32	220	155	4	SE16	K16

Partial 60° Size 16U

Ordering Code		Pitch	
		mm	TPI
16U60D	INT.	4.0-6.0	6-4
	EX.	3.0-5.0	8-5

Coated Grade: BMA

Partial 55° Size 16U

Ordering Code		Pitch
	<th>TPI</th>	TPI
16U55D	INT./EX.	6-4.5

